

## DATA SHEET

# CleanMount Display & Keyboard Station

Crevice Free Design Optimized for Clean Environments

*"The Most Cleanable and Durable Mounting Option in the Industry."*

- ▶ Sealed Cable Passageway; No Exposed Cables
- ▶ 100% Counterbalanced
- ▶ 16" of Vertical Articulation
- ▶ Secure Lock-in-Place Feature
- ▶ Robust Aluminum Construction
- ▶ Display and Keyboard Maintain a Level Position Throughout Vertical Travel
- ▶ Pivoting Ergonomic Display Reduces Glare and Enhances Visibility
- ▶ Dual Swivel Ends Allow for Precise Ergonomic Repositioning
- ▶ Folds to 10" for Convenient Stowaway
- ▶ Five User-Adjustable Sealed Friction Joints
- ▶ Integrated STRONGARM Display and Keyboard are Completely Sealed and Cable-Free



## Specifications

### Adjustability

- Vertical Travel - 16"
- Swivel @ Display End - 180 Degrees
- Swivel @ Mounting End - 180 Degrees
- Display Tilt - Forward 15 degrees, Back 45 degrees

### Materials of Construction

- Body - 356 Aluminum Alloy

### Bearings

- Horizontal Axles - Precision ground ball bearings
- Vertical Axles - Acetal co-polymer bushings

### Displays

- Choose from a variety of STRONGARM display options ranging from 15" to 24W".
- Touchscreen options are available for all STRONGARM displays. (Standard VESA mounting pattern accepts most 3rd party displays.)

### Keyboard

- STRONGARM Mechanical Switch Keyboard with Touchpad pointer (other pointing devices available upon request)
- Also available with a standard keyboard tray.

## Articulation

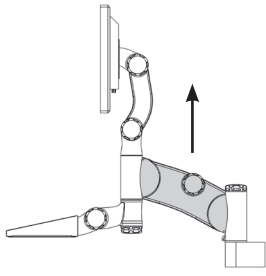

Vertical Articulation

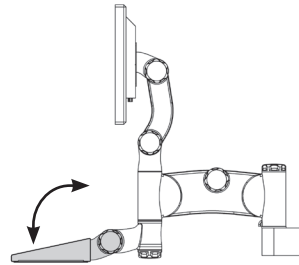
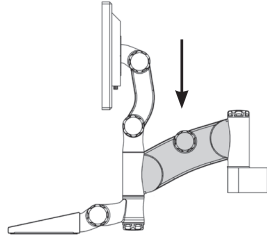

Keyboard Foldup

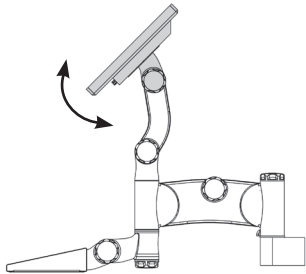
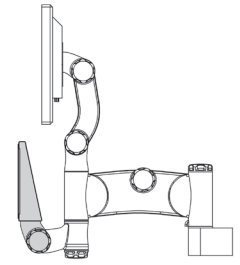

Display Tilt

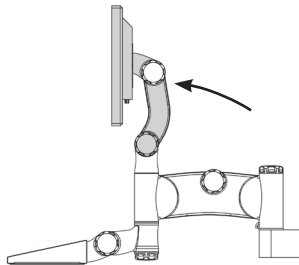
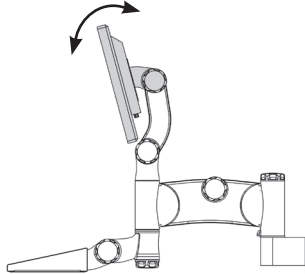

Display Setback

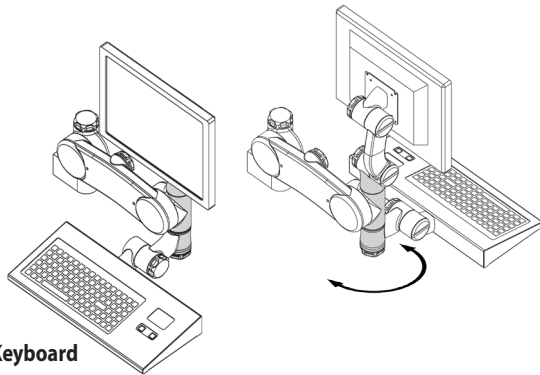
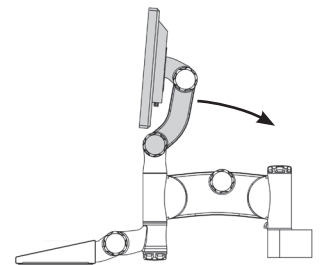

Display/Keyboard Rotation

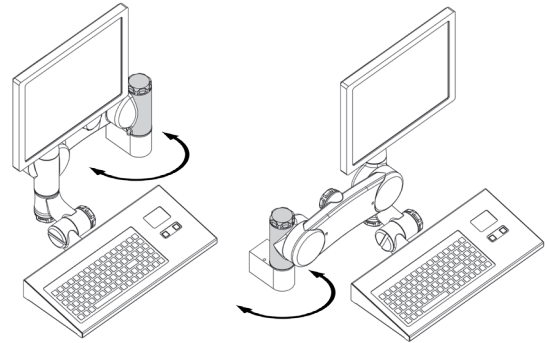

Mounting Rotation

## Dimensions

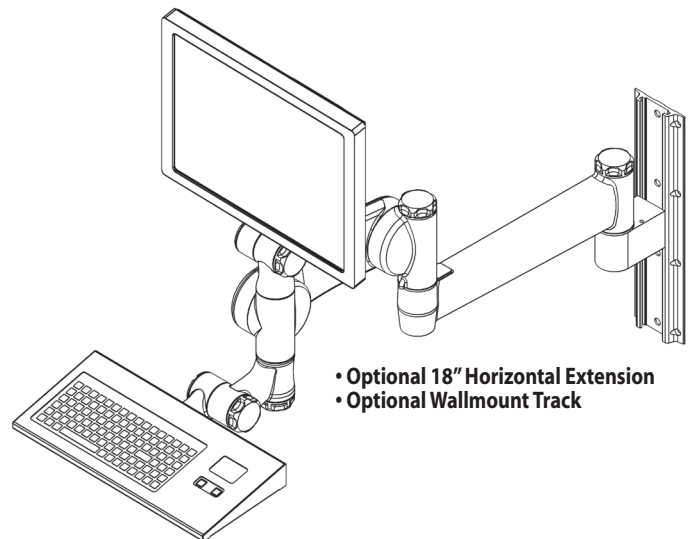
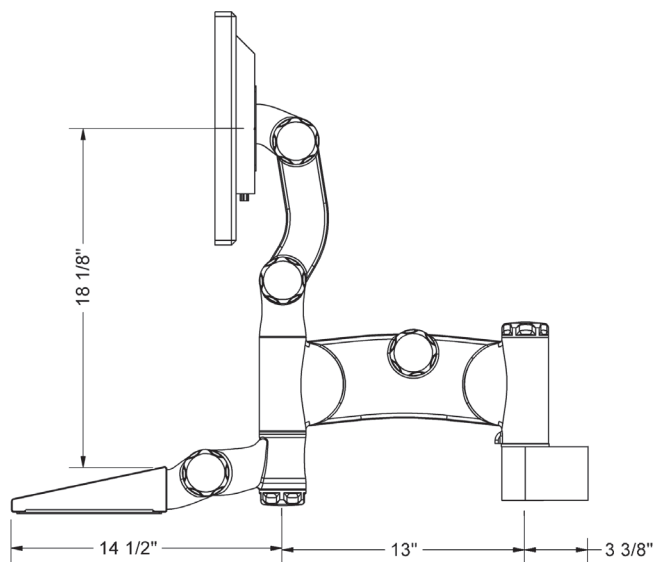

- Optional 18" Horizontal Extension
- Optional Wallmount Track

# STRONGARM®

425 Caredean Drive · Horsham, PA 19044 · 215.443.3400 · Fax 215.443.3002 · [www.strongarm.com](http://www.strongarm.com)

©2011 STRONGARM, Inc.